

# Dual Path Ultrasonic Energy Meter A-ED8



## ABOUT A-ED8

A-ED8 is a product that can carry out bidirectional and independent measurement of heat and cold, meeting the needs of users in different regions. Measure coldness in summer and heat in winter

Uses the latest chip structure design, implement the full digital related technology and intelligent adaptive ultrasonic measurement technology, no moving parts, measurement stability, simple daily maintenance.

A-ED8 has independent flow measurement and temperature measurement circuit, greatly improving the reliability of the whole measurement, flow accuracy can reach 0.5%, temperature measurement is up to 0.02°C limit error, excellent overall performance.

A-ED8 has a friendly menu interface, big display screen, four touch buttons operation, making it no longer difficult to use, at any time query flow, temperature, heat, cold data, can also be daily, monthly and annual query.



## APPLICATION

A-ED8 is widely used in central air conditioning, heating, power plants, paper and pulping, pharmaceuticals and medicine, petroleum, chemical, metallurgy, mining and other flow, heat, cold measurement.

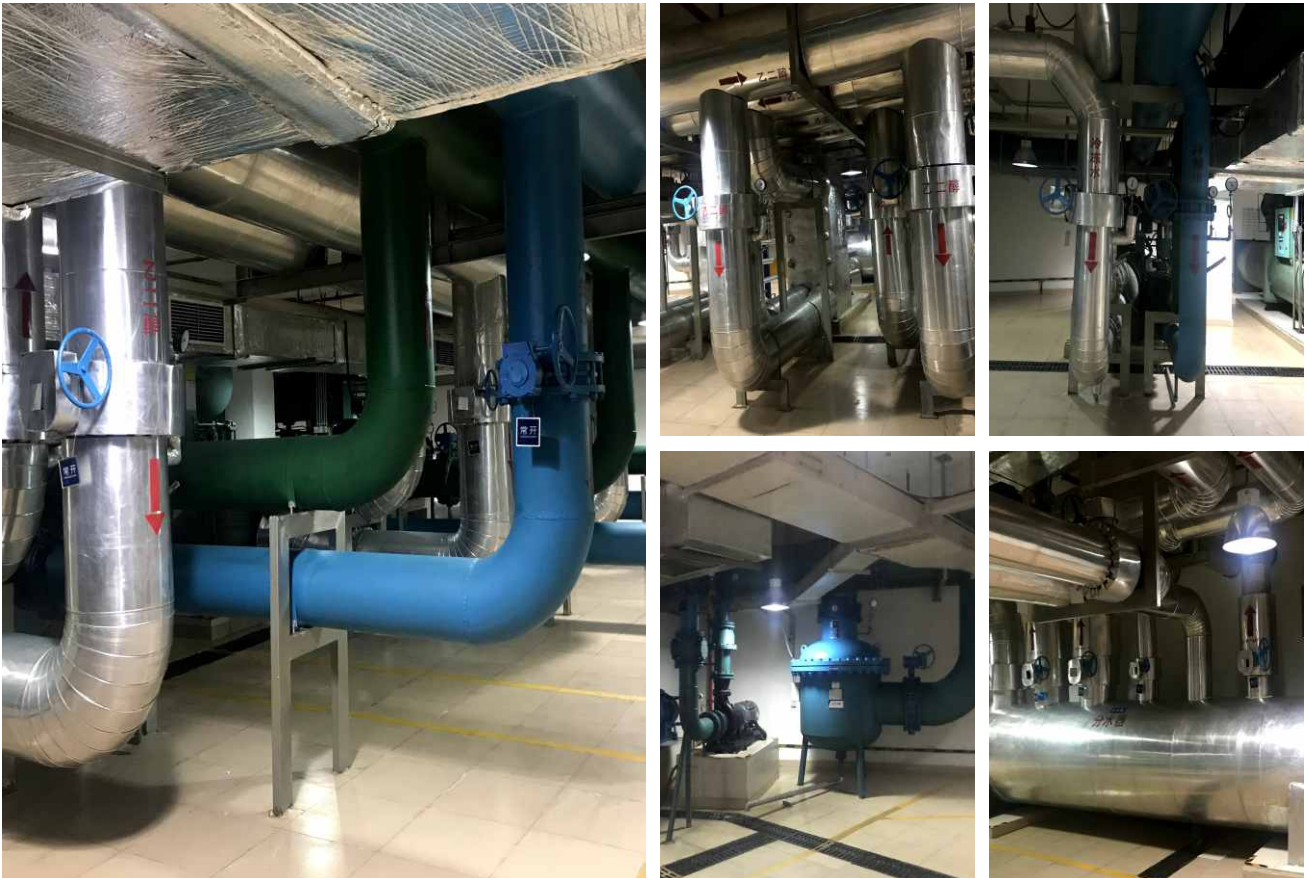

# SPECIFICATION

Performance specifications	
Flow range	0~±40 ft/s (0~±12 m/s)
Flow accuracy	±0.5% of measured value (±0.01m/s~12m/s)
Accuracy of cooling	±1.0%
Pipe size	8 inches to 200 inches (200mm to 5000mm)
Function specifications	
Outputs	Analog output: 4~20mA (max load 750Ω) Pulse output: 0~9999Hz, OCT, (min. and max. frequency is adjustable) Relay output: SPST, max 1Hz, (1A@125VAC or 2A@30VDC)
Communication	RS485, support Modbus communication protocol
Power supply	24 to 36 VDC
Keypad	Four Touch Key
Display	3.5" TFT LCD480*320
Temperature	Transmitter: -40°F~140°F (-40°C~ 60°C) Transducer: -40°F~176°F (-40°C ~ 80°C) (standard)
Temperature range	35.6°F~356°F (2°C~180°C)
Humidity	Up to 95% RH, non-condensing
Physical specifications	
Transmitter	Die-cast aluminum. Enclosure: IP54
Clamp On Transducer	Encapsulated design, double-shielded transducer cable. Standard/maximum cable length: 33ft (10m). Enclosure: IP68
Temperature sensor	Wetted, G1/2, Length 150mm, 3 Wire PT1000, Cable Length: 5m
Weight	Transmitter: approximately 3.3 lb (1.5kg) Transducer: approximately 22 lb (10 kg) (standard)

## Remark

1. Flow Transducer: Wetted(Standard), Optional: Clamp On Transducer
2. Temperature Sensor: Wetted PT1000 (Standard), Optional: Clamp On PT1000 Temperature Sensor

# WIRING DIAGRAM

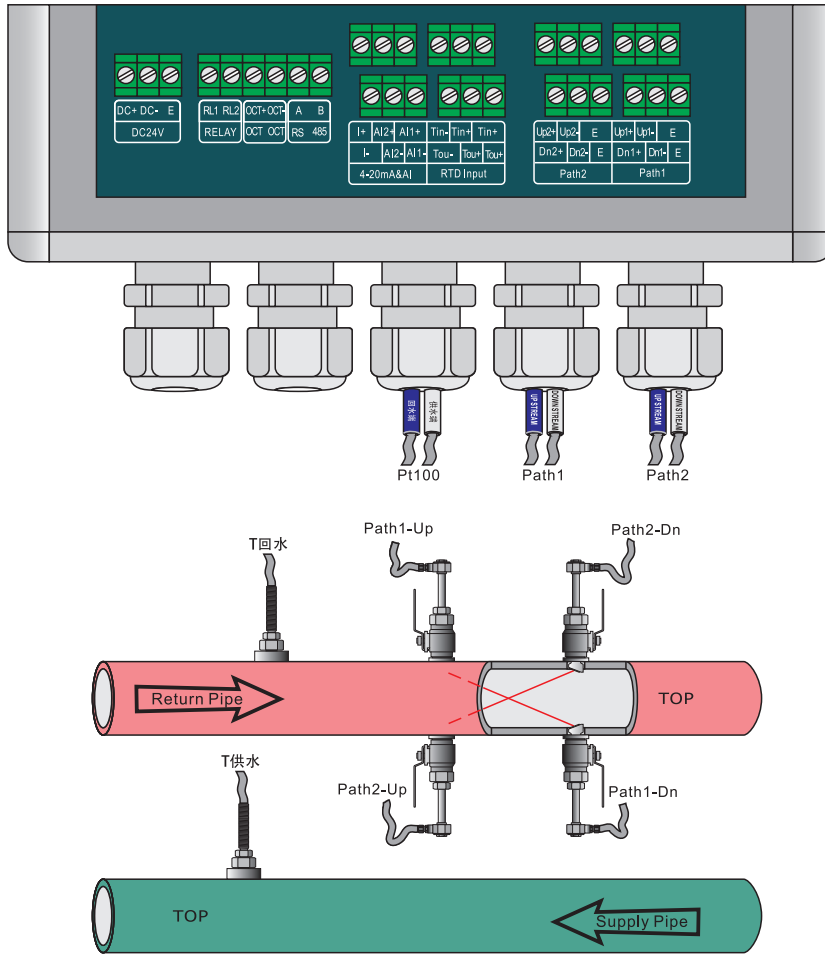

# DIMENSIONS

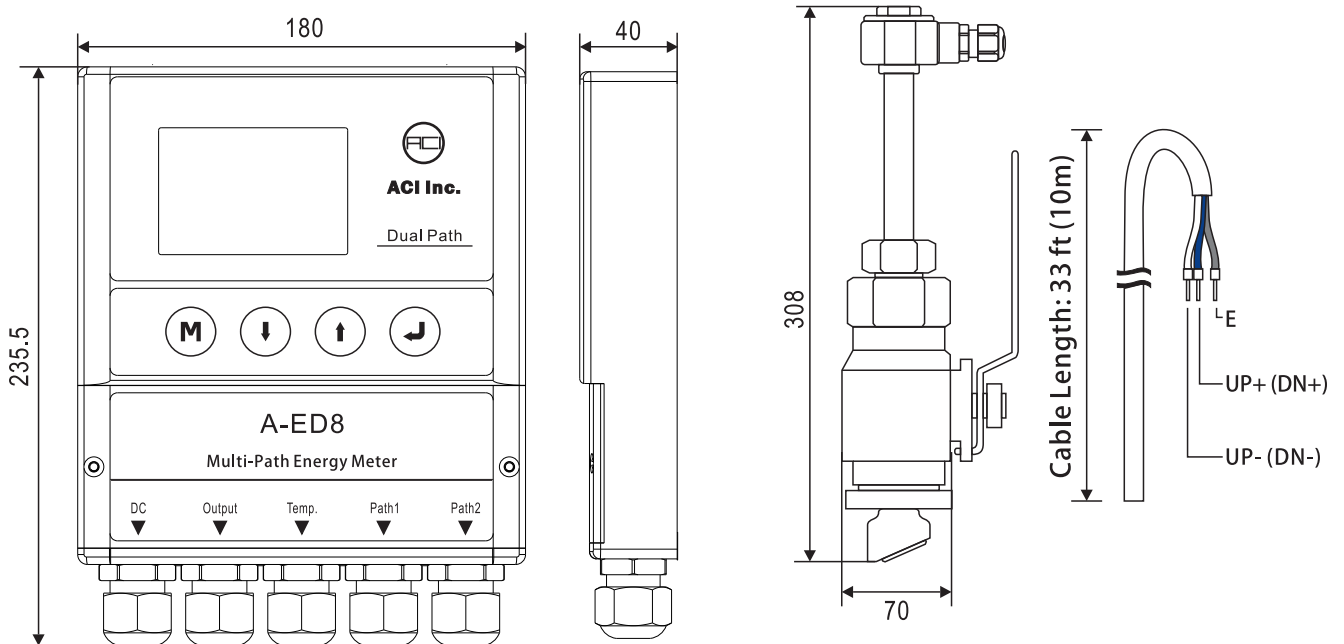

Transmitter dimensions(mm)

Transducer dimensions(mm)

# INSTALLATION METHODS

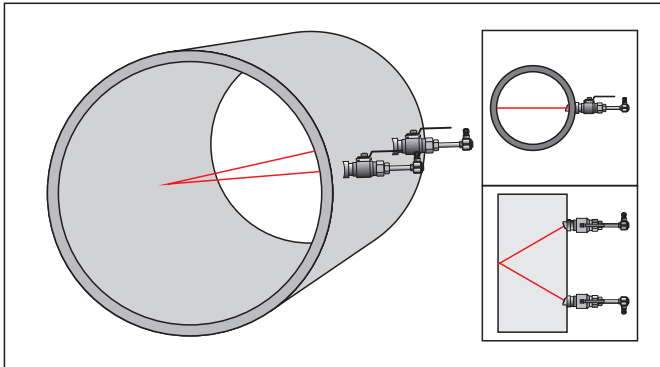

## V Method

The V method is considered as the standard method. It usually gives a more accurate reading and is used on pipe diameters ranging from 200mm to 400mm (8"~16") approximately. Also, it is convenient to use, but still requires proper installation of the transducer at the pipe's centerline and equal spacing on either side of the centerline.

## Z Method

The signal transmitted in a Z method installation has less attenuation than a signal transmitted with the V method. This is because the Z method utilizes a directly transmitted (rather than reflected) signal which transverses the liquid only once.

The Z method is able to measure on pipe diameters ranging from 400mm to 5000mm (16"~200").

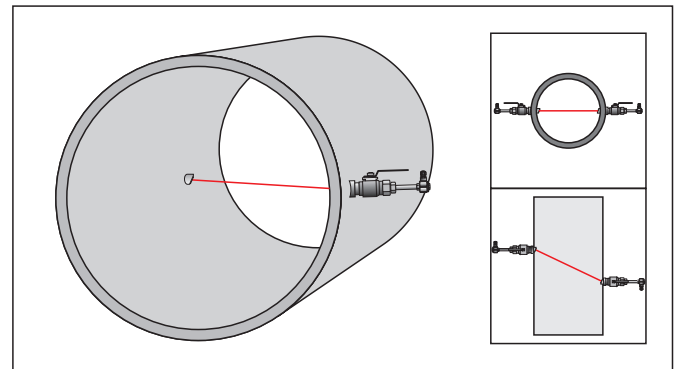

# INSTALLATION SITE SELECTION

Choose a section of pipe, which is always full of liquid, such as a vertical pipe with flow in the upward direction or a full horizontal pipe. Ensure that the fluids temperature at the measuring point is within the transducer temperature limits.

Consider the inside condition of the pipe carefully. If possible, select a section of pipe where the inside is free excessive corrosion or scaling. Choose a section of sound conducting pipe.

Examples acceptable measurement site selection is illustrated on the figure on the below.

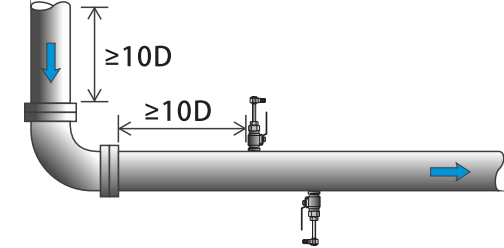
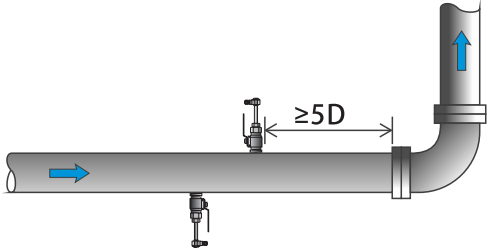
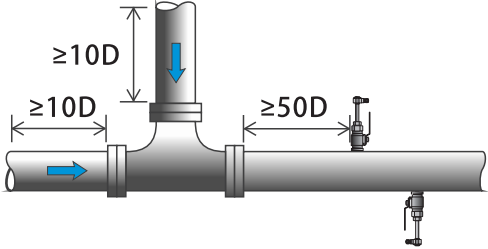
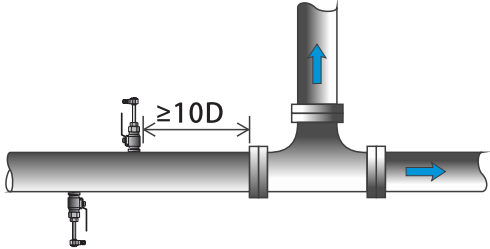
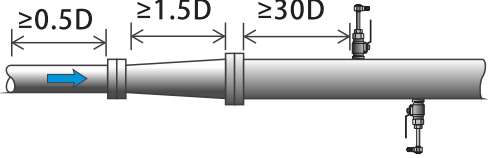
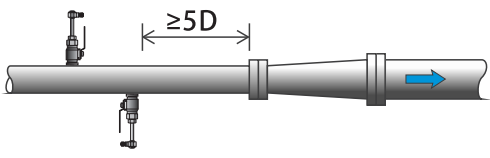
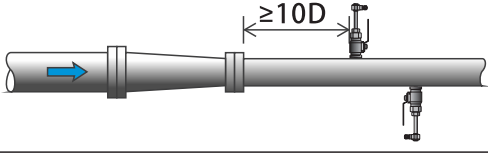
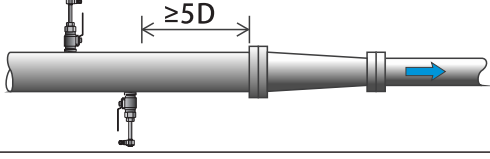
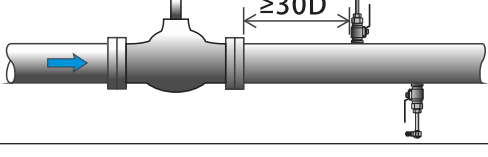
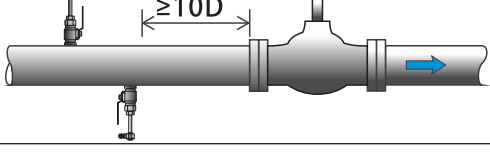
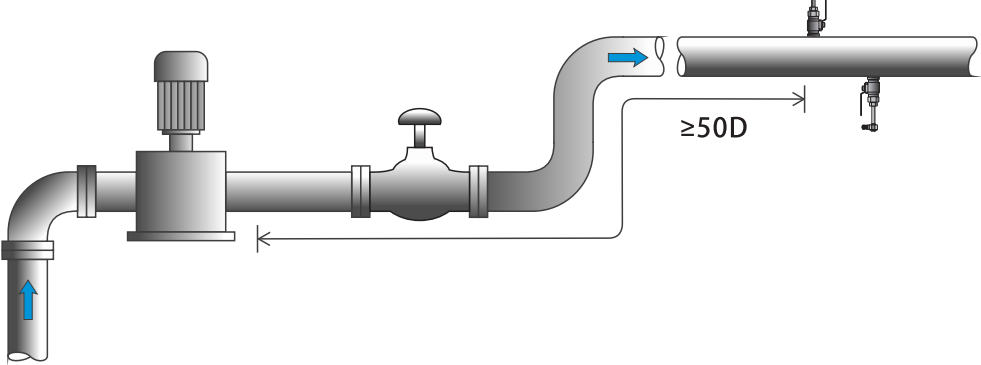
Site	Installation point front straight section	Straight pipe section after installation point
90° bend		
Tee		
Diffuser		
Reduce		
Valve		
Pump		

## ORDERING INFORMATION

Code	Description
A-ED8	<p>Dual Path Ultrasonic Energy Meter A-ED8                      Installation method: Wall mount                      Flow accuracy: <math>\pm 0.5\%</math> of measured value (<math>\pm 0.01\text{m/s} \sim 12\text{m/s}</math>)                      Accuracy of cooling: <math>\pm 1.0\%</math>                      Pipe size: 8 inches to 200 inches (200mm to 5000mm)                      Keypad: Four Touch Key                      Display: 3.5" TFTLCD480*320                      Power supply: 24-36VDC                      Transmitter enclosure: IP54, die-cast aluminum machined enclosure                      Output: 4~20mA, OCT pulse output, relay output                      Communication: RS-485 terminal Modbus Protocol</p>
Code	Transmitter enclosure area classification
1	IP54, die-cast aluminum machined enclosure
2	Customer specific requirements
Code	Tpath Number
1	Singal Path
2	Dual Path
Code	Flow Transducer
W8	Wetted Transducer. Operating temperature: $-40^{\circ}\text{F} \sim 176^{\circ}\text{F}$ ( $-40^{\circ}\text{C} \sim 80^{\circ}\text{C}$ ). Enclosure: IP68
Code	Temperature Sensor
0	User self-supporting
1	PT1000 Clamp on Temperature Sensor. Operating temperature: $35.6^{\circ}\text{F} \sim 356^{\circ}\text{F}$ ( $2^{\circ}\text{C} \sim 180^{\circ}\text{C}$ )
2	PT1000 Wetted Temperature Sensor. Operating temperature: $35.6^{\circ}\text{F} \sim 356^{\circ}\text{F}$ ( $2^{\circ}\text{C} \sim 180^{\circ}\text{C}$ )
Code	Flow Transducer Cable
033	Cable length 33 feet (10m)
xxx	Extended length, up to 656 feet (200m), per 16 feet (5m) is a lengthen unit

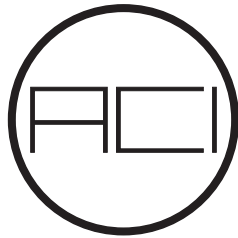

# **ACI Inc.**

---

333 Hudson street, suite#1004  
New York, NY 10013 USA  
[sales@acinstrument.org](mailto:sales@acinstrument.org)  
[www.acinstrument.com](http://www.acinstrument.com)