

Ultrasonic Flowmeter A-X6



ABOUT A-X6

A-X6 is an ultrasonic flowmeter based on transit-time schematic design.

Designed using the digital technology and low-voltage integrated circuit, it have broadband pulse transmission.

While principally designed for full-pipe and clean liquid applications. The instrument is tolerant of liquids with small amounts of air bubbles or suspended solids found in most industrial environments.

Integration design and high integration reduce the link between PCB boards, more reliable.

A-X6 have friendly menu selections make flow meter simple and convenient to use. It can easy to check Daily, monthly and yearly totalized flow. Parallel operation of positive, negative and net flow totalizes.



APPLICATION

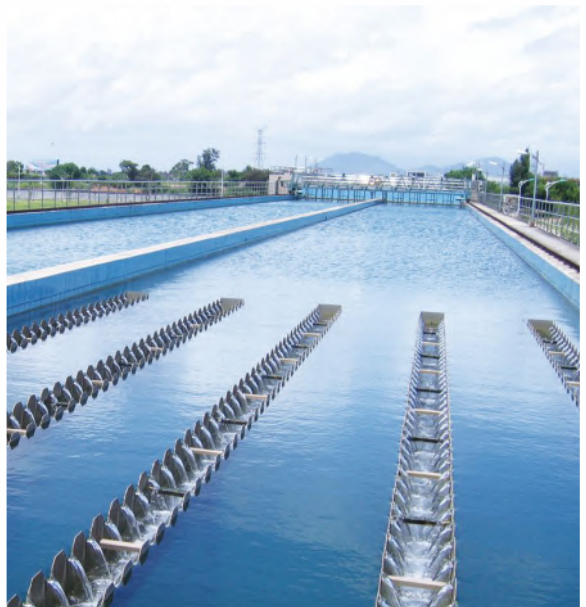

Widely used in chemicals, Irrigation, industrial process water, water supply, water treatment, boiler, etc.



SPECIFICATION

Performance specifications	
Flow range	0~±40 ft/s (0~±12 m/s)
Accuracy	±1.0% of measured value (±0.01m/s ~ 12 m/s)
Repeatability	0.2%
Linearity	±1.0%
Pipe size	1" to 80" (25mm to 2000mm)
Function specifications	
Outputs	Analog output: 4~20mA (max load 750Ω) Pulse output: 0~9999Hz, OCT, (min. and max. frequency is adjustable) Relay output: SPST, max 1Hz, (1A@125VAC or 2A@30VDC)
Communication	RS485, support Modbus communication protocol
Power supply	24 to 36 VDC
Keypad	Four Touch Key
Display	2.2" TFT LCD 320*240
Temperature	Transmitter: -40°F~140°F (-40°C~ 60°C) Transducer: -40°F~176°F (-40°C ~ 80°C) (standard)
Humidity	UP to 95% RH, non-condensing
Physical specifications	
Transmitter	PC Plastic enclosure, Enclosure:IP54
Transducer	Encapsulated design, double-shielded transducer cable. Standard/maximum cable length: 33ft (10m);Enclosure:IP68
Weight	Transmitter: approximately 1.1 lb (0.5kg) Transducer: approximately 2.2 lb (1.0kg) (standard)

WIRING DIAGRAM

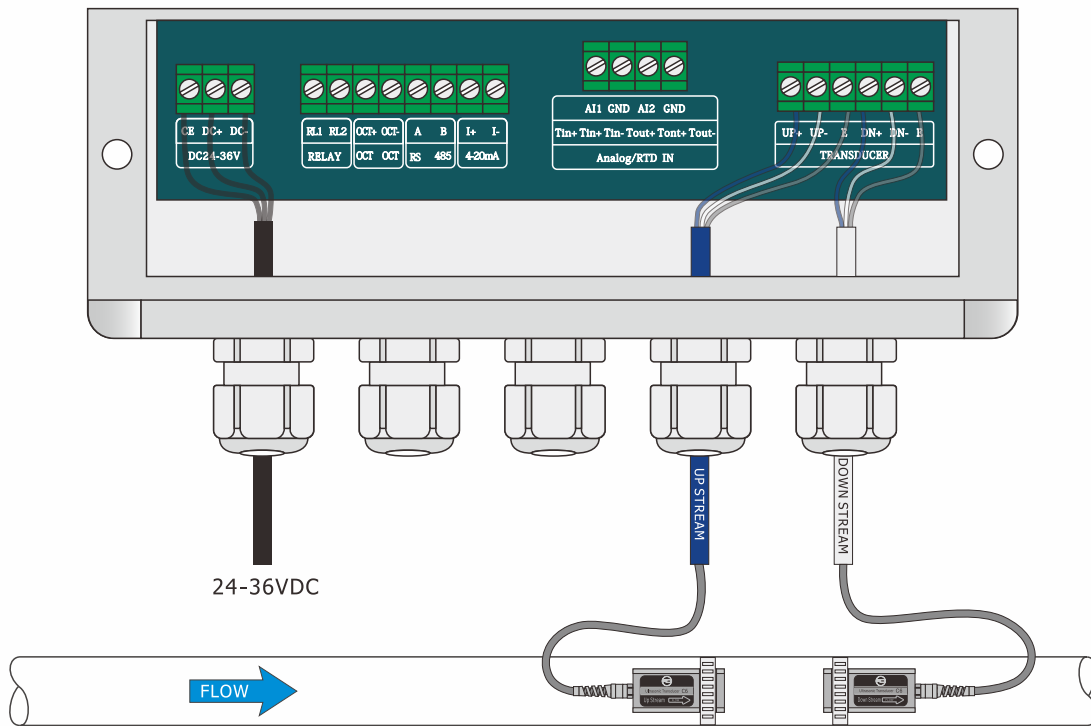

DIMENSIONS

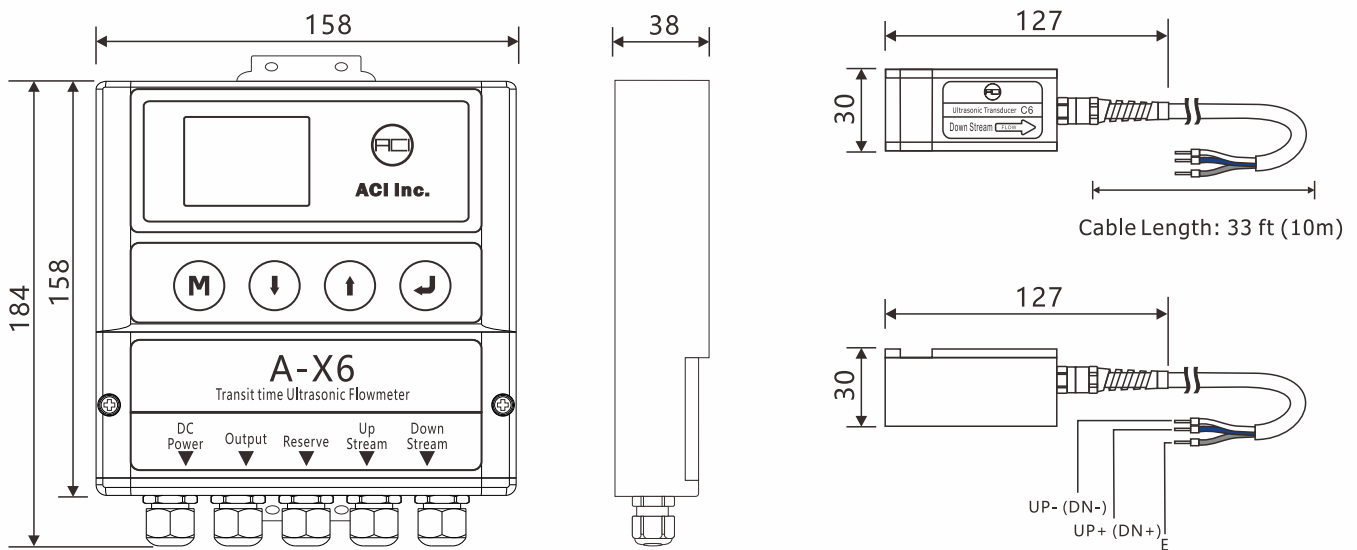

Transmitter dimensions(mm)

Transducer dimensions(mm)

INSTALLATION METHODS

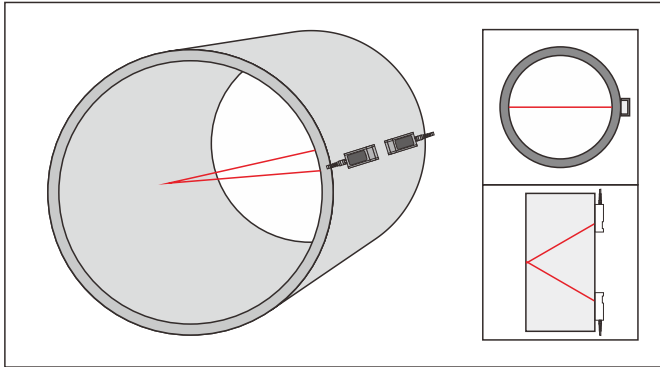

V Method

The V method is considered as the standard method. It usually gives a more accurate reading and is used on pipe diameters ranging from 25mm to 400mm (1"~16") approximately. Also, it is convenient to use, but still requires proper installation of the transducer, contact on the pipe at the pipe's centerline and equal spacing on either side of the centerline.

N Method

With the N method, the sound waves traverse the fluid three times and bounce twice off the pipe walls. It is suitable for small pipe diameter measurement.

The measurement accuracy can be improved by extending the transit distance with the N method (uncommonly used).

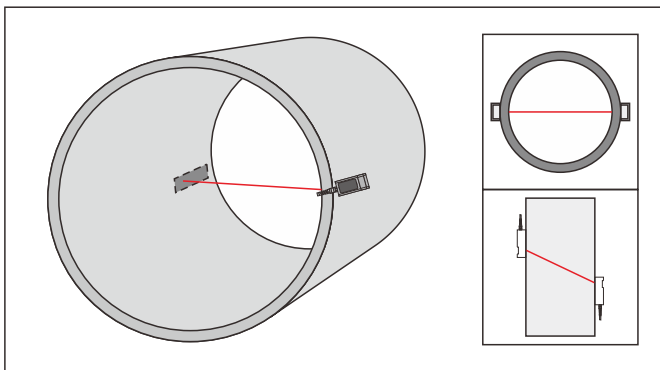
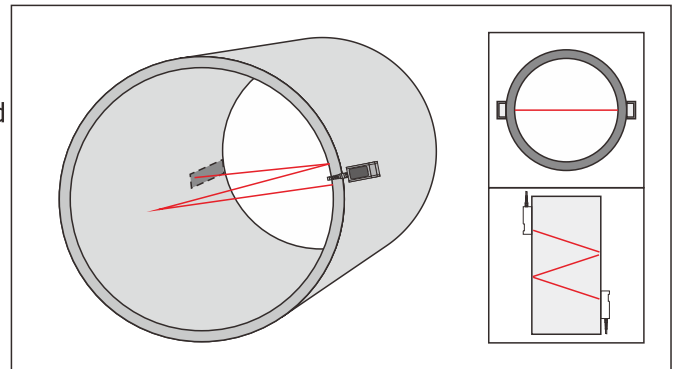

Z Method

The signal transmitted in a Z method installation has less attenuation than a signal transmitted with the V method. This is because the Z method utilizes a directly transmitted (rather than reflected) signal which transverses the liquid only once.

The Z method is able to measure on pipe diameters ranging from 100mm to 2000mm (4"~80").

W Method

As with the N method, the measurement accuracy can also be improved by extending the transit distance with the W method. The sound wave traverses the fluid four times and bounces three times off the pipe walls. It is suitable for very small pipe (diameters less than 50mm, 2").

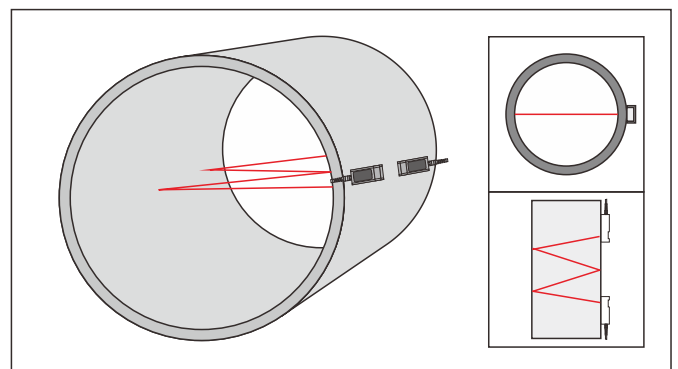

INSTALLATION SITE SELECTION

Choose a section of pipe, which is always full of liquid, such as a vertical pipe with flow in the upward direction or a full horizontal pipe.

Ensure that the pipe surface temperature at the measuring point is within the transducer temperature limits.

Consider the inside condition of the pipe carefully. If possible, select a section of pipe where the inside is free excessive corrosion or scaling. Choose a section of sound conducting pipe.

Examples acceptable measurement site selection is illustrated on the figure on the below.

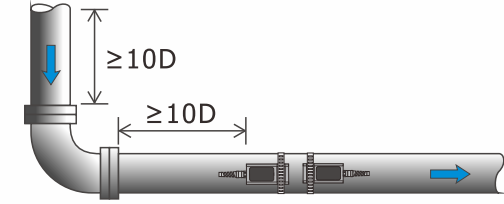
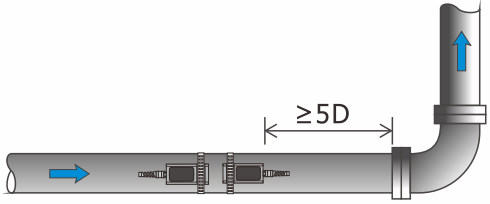
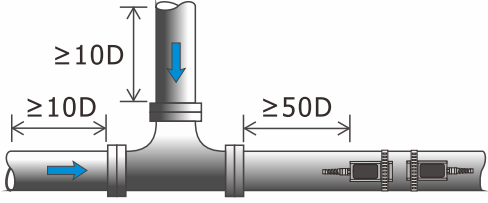
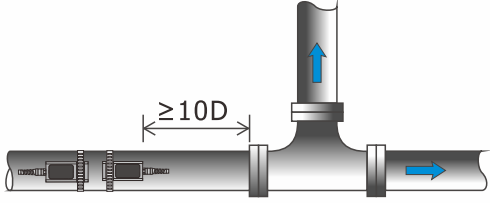
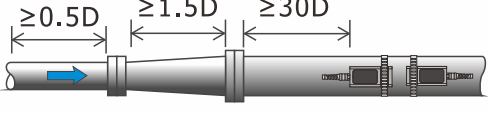
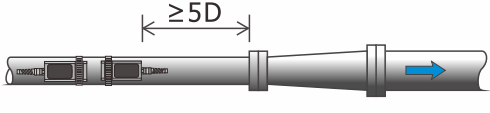
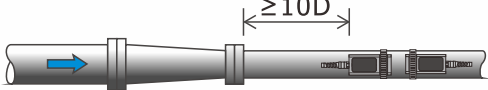
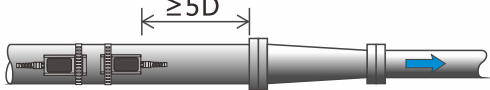
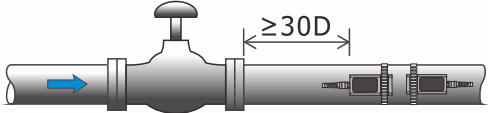
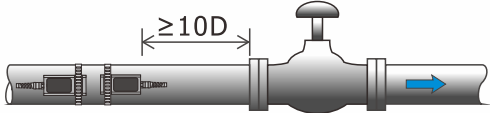
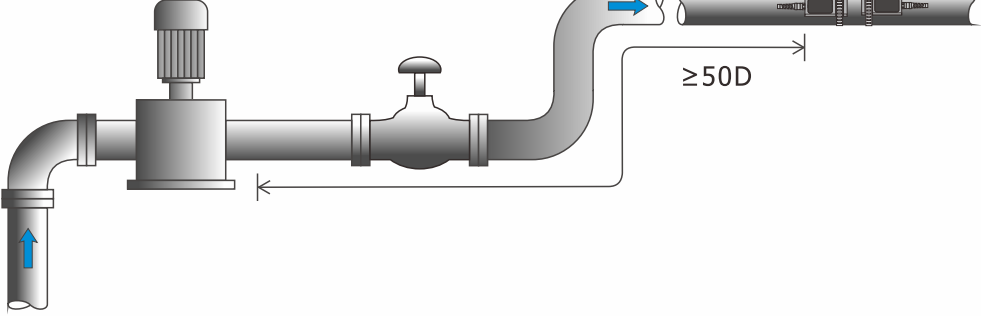
Site	Installation point front straight section	Straight pipe section after installation point
90° bend		
Tee		
Diffuser		
Reduce		
Valve		
Pump		

ORDERING INFORMATION

Code	Description
A-X6	Transit time Flow meter A-X6 Installation method: Wall mount Flow range: 0~±40 ft/s (0~±12 m/s) Accuracy: ±1.0% of measured value (±0.01m/s ~ 12m/s) Repeatability: 0.2% Linearity: ±1.0 Pipe size: 1" to 80" (25mm to 2000mm) Keypad: Four touch keys Display: 2.2" TFTLCD 320*240 Power supply: 24 to 36VDC Transmitter enclosure: IP54, PC Plastic enclosure Output: 4~20mA, OCT pulse output, relay output Communication: RS-485 terminal Modbus Protocol
Code	Transmitter enclosure area classification
1	IP54, PC Plastic enclosure
2	Customer specific requirements
Code	Type of transducers
C6	Clamp on transducer. Operating temperature: -40°F~176°F (-40°C ~80°C); Enclosure:IP68
W6	Wetted transducer. Operating temperature: -40°F~176°F (-40°C ~80°C); Enclosure:IP68
CH8	Clamp on transducer. Operating temperature: -40°F~221°F (-40°C ~130°C); Enclosure:IP68
Code	Transducer cable length
033	Cable length 33 feet (10m)
xxx	Extended length, up to 656 feet (200m), per 16 feet (5m) is a lengthen unit

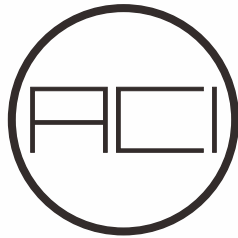

ACI Inc.

333 Hudson street, suite#1004
New York, NY 10013 USA
sales@acinstrument.org
www.acinstrument.com