

## Waterproof Hand-held Infrared Thermometer

### IRT-500-TE

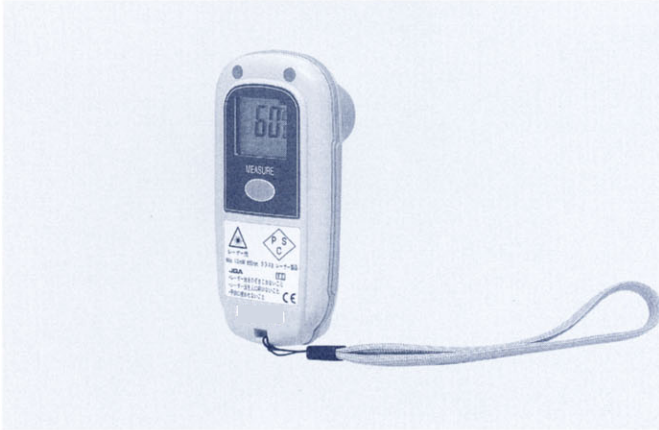

IRT-500-TE is able to determine surface temperature without coming into contact with the object measured.

In accordance with HACCP, it can be used for food processing, storage, distribution and acceptance tests.

It can be used for temperature measurement and control in a wide range of fields including air-conditioning, agriculture, maintenance of electric equipment, testing and research.

#### Features

- IP67 dust-proof/waterproof construction means that it can be used safely when wet. It can even be washed in water.
- It is made of antibacterial ABS resin so it can be used at places such as schools and hospitals.
- Shock-proof construction ensures that it will not break even if dropped from heights of up to one meter.
- Automatically switches itself off to save battery power.
- Portable design ensures that it is small, lightweight and easy to carry without compromising its easy one-touch measurement.

#### Specifications

Measuring range	: -40 to 300°C
Measuring accuracy	: Within $\pm 1\%$ of the measured value $\pm 1$ digit, or within $\pm 2^\circ\text{C} \pm 1$ digit, whichever is greater. However, -30 to 0°C, within $\pm 3^\circ\text{C} \pm 1$ digit less than -30°C, within $\pm 5^\circ\text{C} \pm 1$ digit (Ambient temperature: $25^\circ\text{C} \pm 2^\circ\text{C}$ , at emissivity $\epsilon = 1.0$ )
Repeatability	: Within $1^\circ\text{C} \pm 1$ digit
Response	: Approx. 1second (90% response)
Collimation	: Laser beam (650mm, less than 1mW, JIS class 2)
Indication	: Reflective LCD (3 digits)
Indication resolution	: 0.5°C (However, 1°C for less than -20°C and for 100°C or greater)
Auto power off	: The power is automatically turned off if no key is pressed for approx. 30seconds.
Measuring diameter	: $\phi 45\text{mm}/500\text{mm}$
Emissivity setting	: 0.95 (Default value) The value can be altered between 0.8 and 1.0 by the slide switch (at intervals of 0.05).
Operating temperature	: 0 to 50°C
Operating humidity	: 90%RH (No condensation)
Storage temperature	: -20 to 55°C (No condensation) (Remove alkaline batteries from the IRT-500-TE when it is not in use for a long period)
Battery	: AAA alkaline battery (2 pieces)
Battery life	: Approx. 10 hours of continuous use
Housing material	: ABS resin (antibacterial)
Weight	: Approx. 123g (including 2 AAA alkaline batteries)

#### Safety standards

CE marking	: EN61326-1 Annex-C portable instrument
Protection structure	: Dust-proof/Waterproof (IP67)
Shock-proof	: The IRT-500-TE will be normally performed even if dropped to a vinyl tile floor from heights of up to one meter.

#### Accessories

AAA alkaline battery	: 2 pieces
Strap	: 1 piece
Instruction manual	: 1 copy

#### Relation of distance and measuring diameter

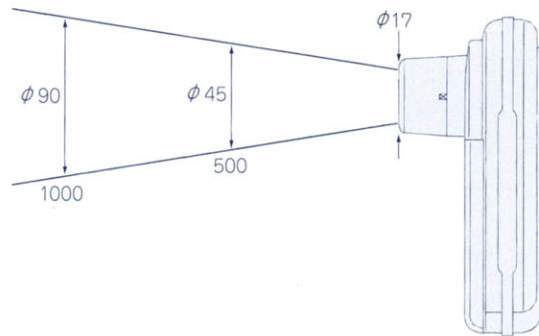

unit : mm

#### External dimension

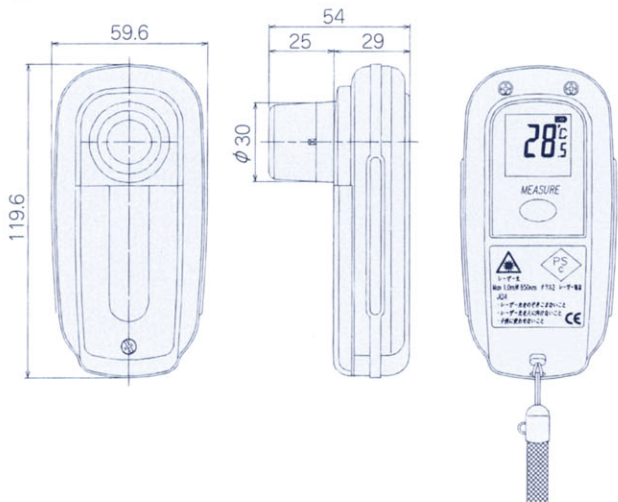

unit : mm

#### Warning

- Do not stare into the laser beam or do not point the laser beam at people's faces.
  - When measuring an object which has a mirror-like surface (glaring metal, etc.), be careful not to be affected by the reflection.
  - Keep this instrument out of the reach of children.
- 
- This catalog is as of August 2003, specifications are subject to change without notice.
  - If you have any inquiries, please consult our agency or the shop where you purchased the unit.