

# **RD-300 series**

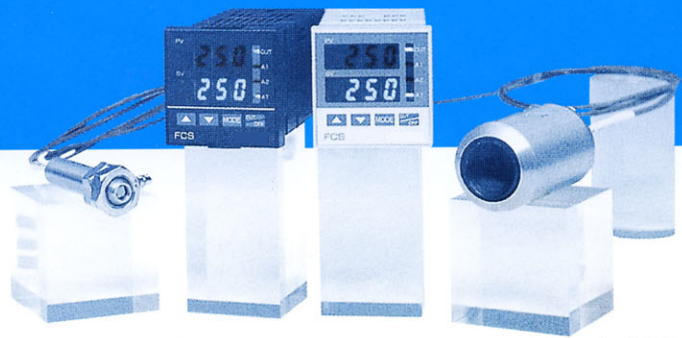

***Infrared Radiation Temperature sensors***

**Generates the same electromotive force as thermocouple K !**  
**Directly connectable to controller !**  
**Quick response time (200ms) !**



▲ When connected to the Digital controller FCS-100.

**●Temperature sensing by infrared radiation means non-contact temperature measurement !**

- Small and light-weight.
- Power supply or converter unnecessary.
- Degrades slower than a thermocouple.
- Vibration-proof, Shock-proof and High sealing performance, Splash-proof (IP67).

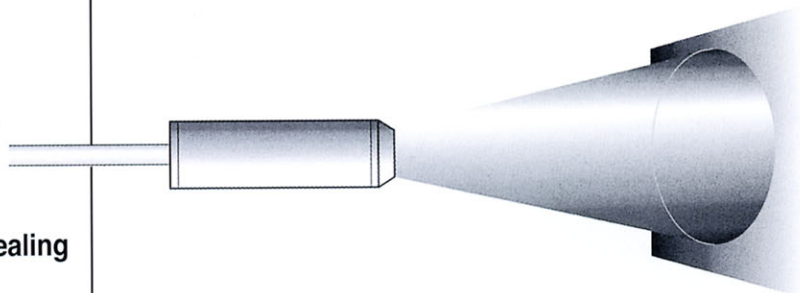

**●The non-contact type is applicable in the following cases.**

- Bearings for shafts
- Vacuum forming
- Vehicle tires
- Vacuum furnaces
- Semiconductor devices during manufacturing
- Printed circuit boards during manufacturing
- Objects being moved by conveyor
- Dough kneading processes for bread, cake, etc.
- Roller and film for laminators
- Printing ink, Rollers for printing
- Drying processes for wood, paper or fiber
- Environmental (heat) control for hazardous materials
- Hot melt adhesives
- Glass during manufacturing
- Rollers for weaving machines
- Asphalt
- Culture petridishes
- Food, Medicine
- Other objects which requires non-contact temperature measurement.

**●Measurement by infrared generally has the following strong points and weak points.**

- Non-problematic objects (Most of the nonmetal surface)  
Food, Paper, Plastic, Coated metal, Stone, Soil, Glass, Liquid and Fiber
- Problematic objects\*  
Lusterless metal or Thin transparent plastic
- Difficult objects\*  
Plated lustrous metal or Non-coated metal

In cases where measurement is difficult, it can be made easier if the black body tape is used to raise the emissivity.

\*Even if the measured value is different from the actual temperature due to emissivity of the measured object on site, the process and quality can be managed by the measured value because the RD-300 has the repeatability.



**External dimensions unit : mm**

**RD-301**



**RD-302**

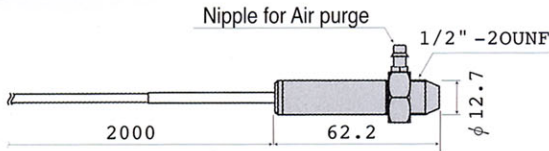

**RD-305**

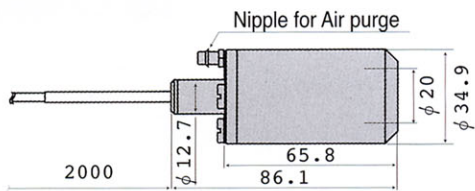

**RD-310**

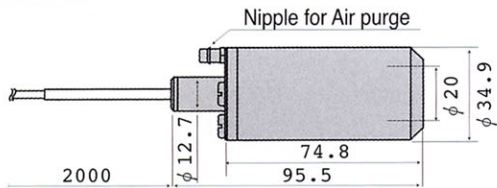

**Standard specification**

Model	RD-301	RD-302	RD-305	RD-310
Measuring range	-18 to 25 (*1), 25 to 80, 70 to 105, 90 to 120, 115 to 155, 145 to 190, 180 to 250°C			
Accuracy	When the emissivity of the object is 0.9, it is ±3% of the indicated value or 3.3°C, whichever is greater. (However, for the range 180 to 250°C, ±5% of the indicated value.)			
Angle of visibility	Approx. 53°	Approx. 28°	Approx. 11°	Approx. 6°
Minimum measuring diameter	φ 8mm	φ 4mm	φ 20mm	φ 20mm
Measuring distance : Visual field diameter	1 : 1	2 : 1	5 : 1	10 : 1
Repeatability	±1% of the measured value or 1°C, whichever is greater.			
Temperature coefficient	0.04% of the indicated value per ambient temperature change 1°C			
Measuring wave length	6.5 to 14.0 μ m			
Detection element	Thermopile			
Output	Electromotive force of the thermocouple K			
Response time	200ms (at 63.2% response)			
Output impedance	Approx 3k Ω	Approx 4~8k Ω (*2)	Approx 4~8k Ω (*2)	Approx 4~8k Ω (*2)
Allowable ambient temperature	-18 to 100°C			
Air purge	Not applicable	Aplicable	Aplicable	Aplicable
Allowable maximum temperature	100°C	120°C (*3)	230°C (*3)	230°C (*3)
Dielectric strength	Between body and cable, 500Vac for 1 minute			
Housing	Closed structure, Splash-proof structure, IP67 (excluding cable part)			
Material of light receiving opening	Silicon lens			
Case material	SUS303 equivalent			
Output cable	Thermocouple wire, length 2m (Teflon coating, Heat-proof 200°C)			
Weight (Body)	Approx 40g	Approx 47g	Approx 187g	Approx 197g
External dimension	φ 12.7×44.5mm	φ 12.7×62.2mm	φ 34.9×86.1mm	φ 34.9×95.5mm

\*1 : The measuring range -18 to 25°C is not available for the type RD-310.  
 \*2 : It is different depending on the measuring range.  
 \*3 : Allowable maximum temperature in case of air cooling by using attached air purge parts.  
 Note : Output cables are to be connected Yellow to (+) and Red to (-).

**Measuring distance : Visual field diameter unit : mm**

**1 : 1**

● Visual field diameter is the same measure as the distance

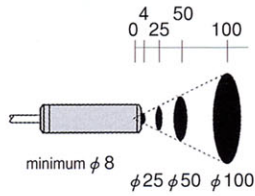

**2 : 1**

● Visual field diameter is approx. 1/2 of the distance

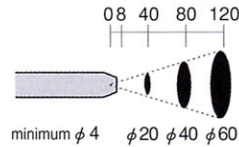

**5 : 1**

● Visual field diameter is approx. 1/5 of the distance

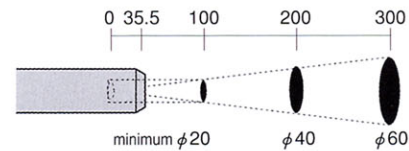

**10 : 1**

● Visual field diameter is approx. 1/10 of the distance

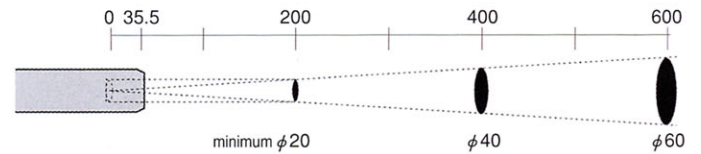

**Measuring range**

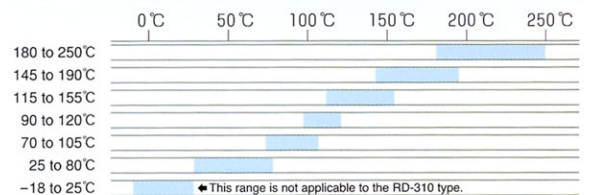

**Mounting bracket (Sold separately) unit : mm**

● T type small (for RD-301, 302)      ● MB-1 type (for RD-305, 310)

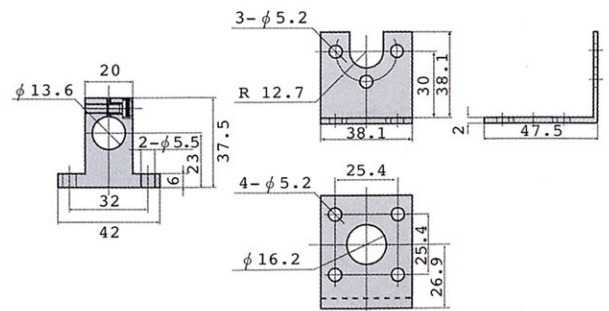

**Recommended controllers to be combined**

● Providing the Fuzzy self-tuning PID control

**FC series**

- FCS-200 series (48×48mm)
- FCR-100 series (48×96mm)
- FCD-100 series (96×96mm)

# RD-300 series Q & A

## Q How is temperature detected ?

A

The infrared technique involves receiving heat energy radiated from a measured object, and converting the energy into electric potential energy.  
The output is designed so as to agree with the characteristics of the thermocouple K, and the linear part is used within the accuracy.

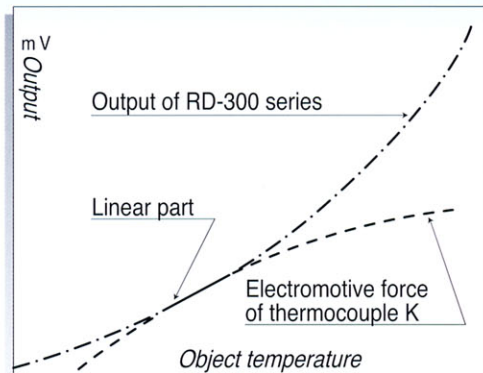

## Q How large is the measuring object ?

A

It can be measured from a minimum  $\phi$  4mm when the RD-302 type is used.  
(Refer to the section, Measuring distance : Visual field diameter.)

## Q What is Emissivity ?

A

Emissivity is related to the reflection factor. The reflection factor is "0" when the object surface does not reflect at all. That is, the emissivity is 100%, namely "1". Such an object is called a black body.  
The reflection factor of a lustrous metal surface is 80 to 95%, therefore, the emissivity will be 0.05 to 0.2, accordingly, it is difficult to measure the lustrous metal surface by infrared.  
However, measurement is possible when using black body tape.

## Q Is it possible to use the sensor in a steamy environment ?

A

Generally, it's harder for infrared wavelengths to pass through steam, and it makes the temperature detected rather lower than actual. If the steam condenses on the sensor lens, the sensor will not function.  
The RD-302 type with air purge is recommended in such an environment. It makes measurement possible by blowing off the steam with the air from the top.  
The air is effective in preventing the condensation on the lens surface as well. When using the air purge, take care not to cool the object by air.  
Air purge is used to protect the body from flammable gas, corrosive gas, dust, etc. by blowing air.  
With the RD-300 series, it is used to cool the body and to protect the lens from dirt or dewing.

## Q In what environmental temperature should I mount the sensor ?

A

In cases of 100°C or less, any type can be used. If temperature exceeds 100°C, a cooling system (air purge) is required to protect the sensor. The RD-302, 305, and 310 types are available for these systems. When the environmental temperature is 260°C or more, it is best to provide a water cooling jacket to the RD-301, 302 types. (Please make inquiries.)

## Q What is the cable length when fully extended?

A

It is possible to reach a maximum length of 300m if a compensating lead wire is connected.

### ■ When ordering,

1. Select the model name by Angle of visibility, Minimum measuring diameter, Measuring distance : Visual field diameter, Air purge applicable or not and External dimension.
2. Select the temperature range to be measured.



- To ensure safe and correct use, thoroughly read and understand the manual before using this instrument.
- This instrument is intended to be used for industrial machinery, machine tools and measuring equipment. Verify correct usage after consulting purpose of use with our agency or main office.  
(Never use this instrument for medical purposes with which human lives are involved.)
- External protection devices such as protection equipment against excessive temperature rise, etc. must be installed, as malfunction of this product could result in serious damage to the system or injury to personnel. Also proper periodic maintenance is required.
- This instrument must be used under the conditions and environment described in the manual. Shinko Technos Co., Ltd. does not accept liability for any injury, loss of life or damage occurring due to the instrument being used under conditions not otherwise stated in this manual.

### Caution with respect to Export Trade Control Ordinance

To avoid this instrument from being used as a component in, or as being utilized in the manufacture of weapons of mass destruction (i.e. military applications, military equipment, etc.), please investigate the end users and the final use of this instrument.  
In the case of resale, ensure that this instrument is not illegally exported.